

GLOBAL

series Cutting Machine

INSTRUCTION MANUAL

I. Uses and characteristics.

- 1.It is suitable for cutting various kinds of cloth,sponge and leather.
- 2.It is easy to operate.
- 3.The contacting parts of driving pulley and band knife are made of wear-resisting material, and thus resulting long service life and low noises.
- 4.Driving pulley adopts large diameter(Φ 300mm) design to protect band knife from being broken.
- 5.stepless speed adjusting by converter,it is easy to change cutting speed.
- 6.The product adopts cushion system,and the material can be moved smoothly and flexibly in cutting operation.

II.Description of all parts.(Fig.1,2,3)

No.	Description
1	machine frame
2	long guard pipe
3	lower guard
3A	Stroke
4	short guard pipe
5	digital keypad
6	switch box
6A	Switch
7	height adjusting screw
8	machine support mounting pad
9	movable roller
10	front cover
11	machine support
12	metal plate of table
13	metal plate with holes
14	table support
15	cutting table
16	guide block
17	grinding wheel device
18	upper guard
18A	Stroke
19	tension bar
20	tension box
20A	Switch
21	converter
22	main motor
23A	Stroke
23	band knife
24	blower
25	driving wheel

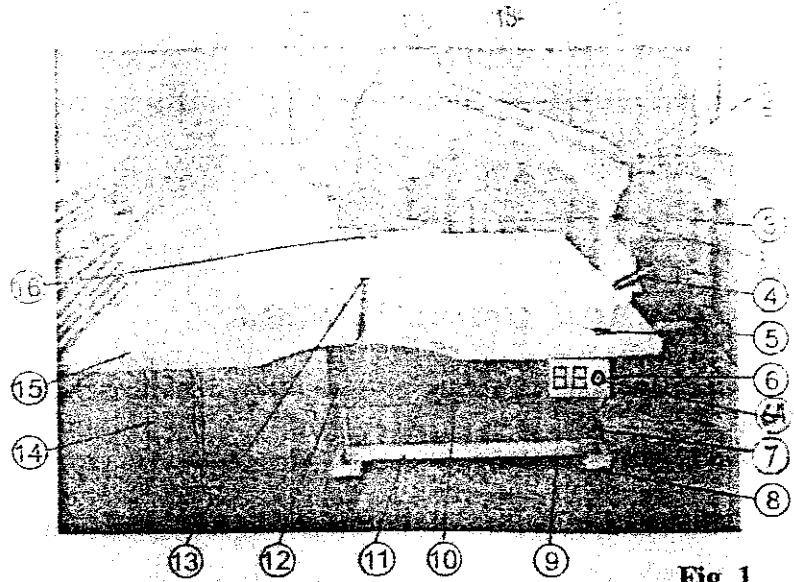

Fig. 1

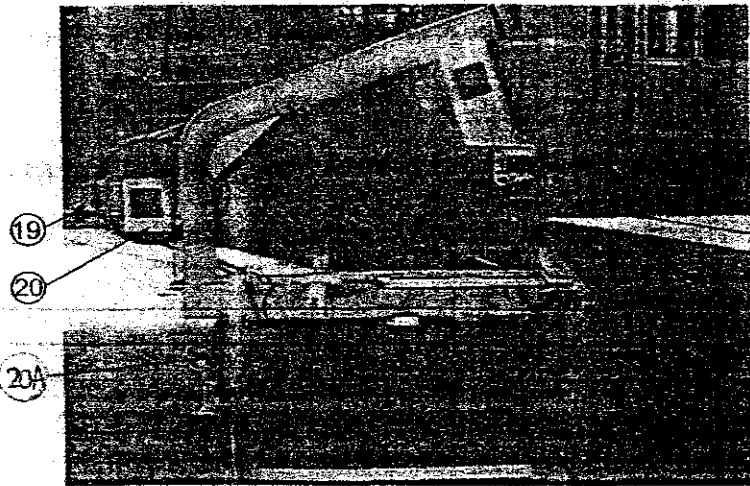

Fig. 2

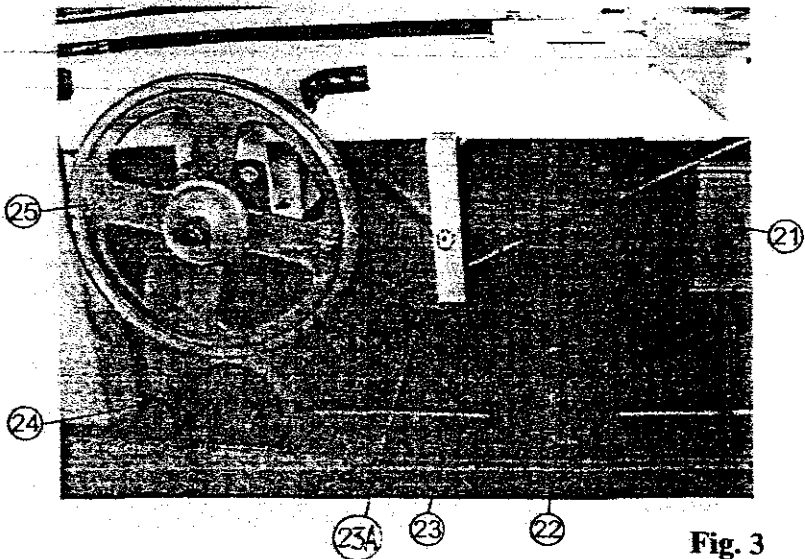

Fig. 3

Caution: Stroke (3A, 18A) adjusted on the inside of hood shield(3, 18)

III. Installation.(Fig.4,5)

1. Align holes in table (3-1) with nuts (3-2) on machine support,then retighten screws (3-3) to lock nuts.
2. Loosen nut (9-2),turn screw 9 to set the table to required height.Then retighten nut.
3. Loosen nut (4-2),turn screw 4-1 of table support until the table rest on the support bar.Then retighten nut (4-2).

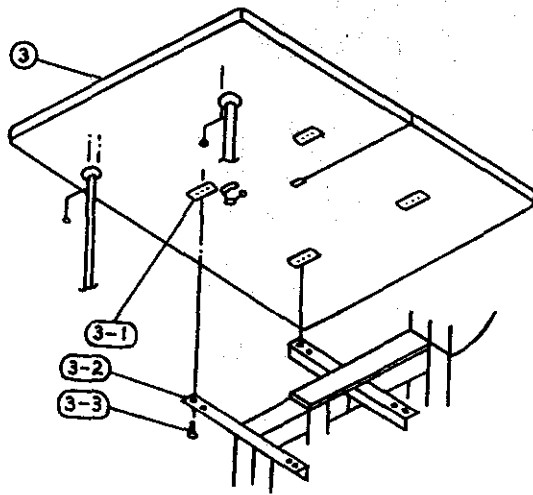

Fig. 4

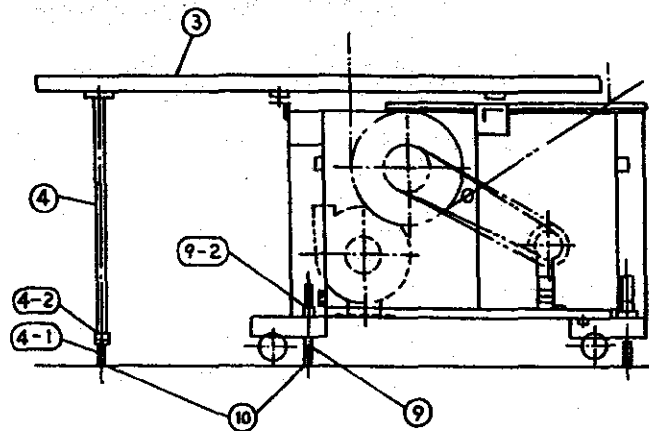

Fig. 5

IV. Operation.

1. Depends on thickness of materials,rotate rotary button to adjust guide block and protection device to the lowest position(Fig.6).
2. Turn on the band knife and blower with switches in boxes located at the right side beneath the table on.
3. Press down the material to cut with hands,and make it contact with band knife.Move the material all around to achieve the desired forms.

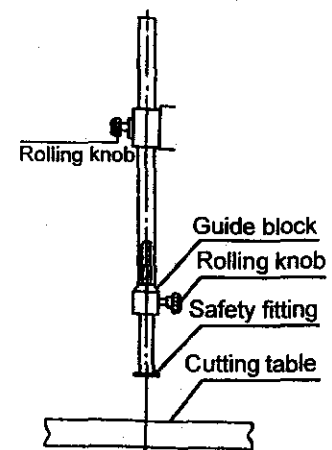

Fig. 6

Notice:

1. Take care of the band knife in operation.
2. Do preparing for the next cutting process only with the machine turner off.

V. Grinding.

1. Grinding the knife when the knife becomes dull and the blade is dirty.
2. As shown in Fig.7,pull the grinder lever to start grinding.
3. If the grinding wheel is unable to reach the band knife after pulling the grinder lever,then loosen the nut,and turn the wing screw to make the mat move forward a little way (Fig.8).

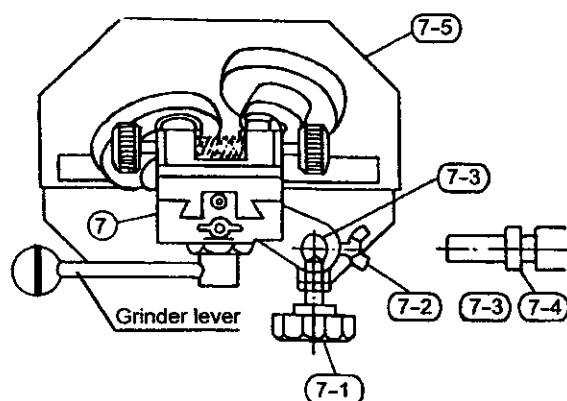

Fig. 7

Notice: Only a little way should be moved,or the band knife will be pressed by the grinding wheel,it is impossible to grind the knife.

4. If the blade is ground unevenly as shown in Fig.9, then adjust the two grinding wheels left or right by turning the two knurled screws(7-6) shown in Fig.10.The arrows in Fig.9 indicate the moving direction of the grinding wheels.

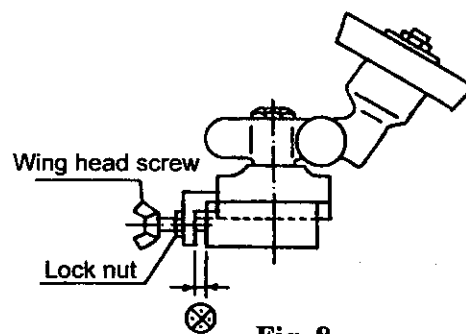

Fig. 8

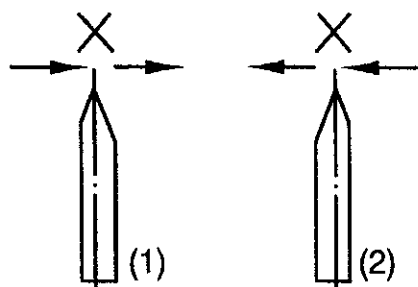

Fig.9

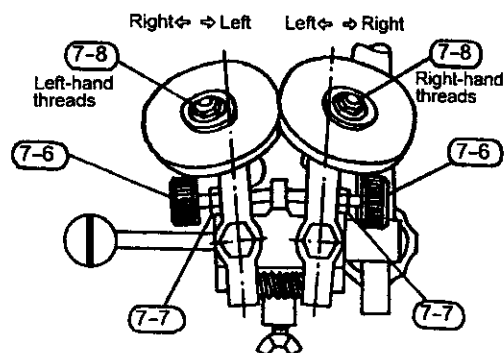

Fig. 10

5. Generally, the angle between two blades should be small for thin materials, and the angle should be big for heavy materials. Refer to Fig.10 for details, and the small arrow indicates the moving direction of two grinding wheels.

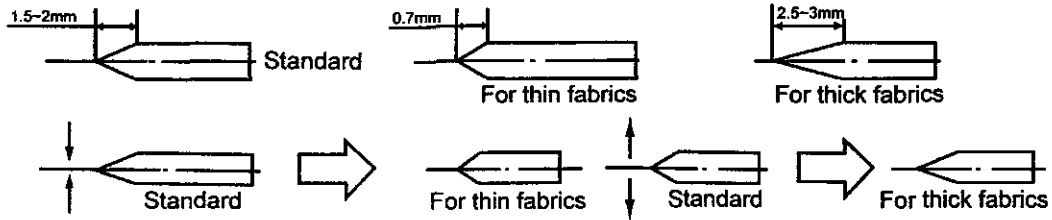
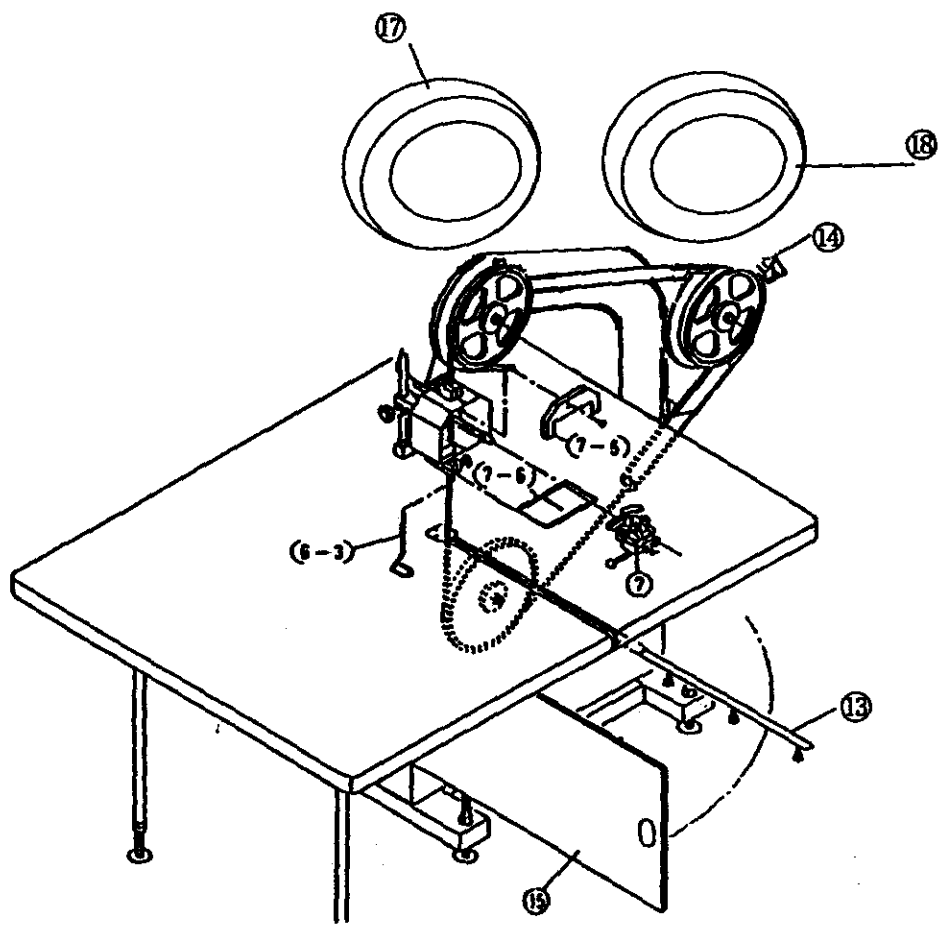

Fig.11

6. The worn grinding wheels can be used continuously by moving them closely.
7. If the knife is not ground though the grinding wheels has been adjusted correctly. The grinding wheels are worn out and should be replaced. Loosen nuts shown in Fig.10 to replace.

VI. Replacement of the band knife.

1. The knife should be replaced when the width of the knife is reduced to smaller than 5 mm by several times ground.
2. Remove two round guard covers 17 and 18 (Fig.12) on the machine frame.
3. Remove front cover, guide block and protection device of the grinding device.
4. Loosen the wing nut beneath the machine table to pull out strip plate 13.
5. Rotate the tension bar 19 (Fig.2) to make the band knife loose for replacing.



VII.

Digital keypad operation

1. Description and Function of the Digital Keypad

When delivered from the factory, the digital keypad module is mounted on the front panel of the AC drive. This module has two parts: a display panel and a keypad. The display panel allows the user to program the AC drive, as well as view the different operating parameters. The keypad is the user interface to the AC motor drive. Refer to the following figure for a description of the different parts.

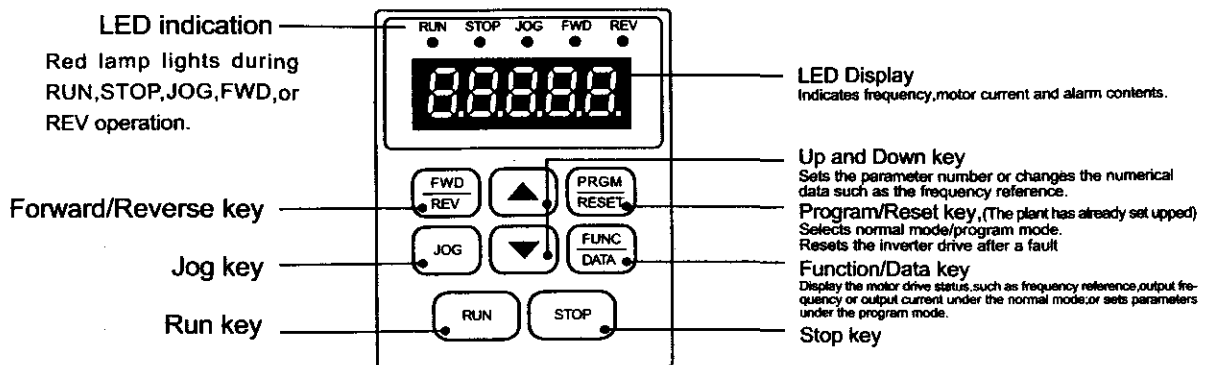

Program/Reset

The plant has already set upped, according to this key, it is invalid.



Function/Data

Displays information on the AC drive status such as the reference frequency, output frequency, or output current in the normal mode. While the drive is in the Program Mode, press this key once to display the current parameters. After changing the parameters, press this key again to store the new parameters.



Forward/Reverse

Used to toggle between forward and reverse operation.

Pressing this key will cause the motor to ramp down to 0 Hz and then ramp up to the preset speed in the opposite direction. By default, the digital keypad controls the AC drive forward/reverse operation. To control the forward/reverse operation via the control terminal block, change the Pr.01 parameter to "d0001" or "d0002".



JOG

Used to start the AC drive, then run at the jog frequency as set by the parameter specified under Pr.23 [Jog Frequency].



RUN

Used to start the AC drive operation. This key has no effect when the drive is set to terminal run.



STOP



Used to stop the AC drive operation.

















Up / Down



Press the Up or Down button to change parameter settings. These keys may also be used to scroll through different operating values or parameters.

Note: Pressing the  or  button momentarily changes the parameter settings in increments. Press and hold down either of these keys to rapidly run through the possible settings.

● Explanation of Displayed Messages

Displayed Message	Description
	Displays the AC drive output frequency controlled by the Maximum Output Frequency(Pr.03), Jog Frequency(Pr.16), or by the Multi-Function Input Terminals(Pr.39-41). If the frequency source originates from the Digital keypad, the user can use either the  or  key to set the frequency.
  	Displays the output frequency present at terminals U, V, and W. Displays the custom unit(v), where $V=H \times \text{Pr.65}$ Displays the internal counter value(C).
	Displays the output current present at terminals U, V, and W.
	Displays the specified parameter number. The actual parameter value may be displayed by pressing the  key.
	Displays actual value stored within the specified parameter. Press the  key to store the value of the specified parameter.
	The display will read end(as show) for approximately 1 second if the input has been accepted. After a parameter value has been set, the new value is automatically stored in memory. To modify an entry, use  or  key, then press the  key.

● Explanation of the LED Indicators

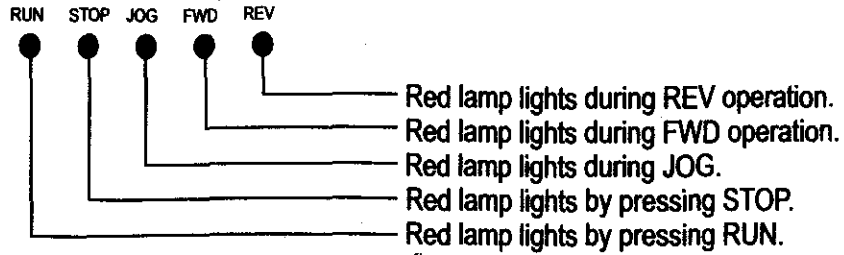

RUN or STOP lamp indication is defined by the following operation

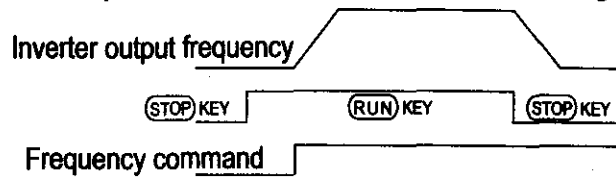

RUN LAMP	●	☀	☀	☀	☀	●
STOP LAMP	☀	☀	●	●	☀	☀

☀ LIGHT ☀ BLINK ● LIGHT OFF

FWD or REV lamp changes indication is defined by the following operation

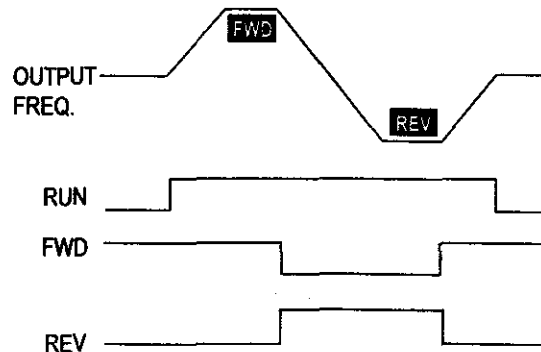

FWD LAMP	☀	☀	☀	●	☀	☀
REV LAMP	●	●	☀	☀	☀	☀

☀ LIGHT ☀ BLINK ● LIGHT OFF

