

**The**

**GLOBAL**

**Selection**

---

**333 SK**

**HIGH SPEED LOCKSTITCH SEWING MACHINE WITH  
EDGE CUTTER**

**Service manual**

**Parts catalog**

# ATTENTION:

To avoid wrong performance of sewing machine or potential damage towards it , make sure of the following items before operation:

- Wipe and clean the machine before initial operation.
- Oil the machine after cleaning it.
- The voltage is correct.
- Plug is properly connected.
- Running under improper voltage is strictly forbidden.
- Motor pulley rotates in right direction.

## 1. MAIN SPECIFICATIONS

- |                          |                                       |
|--------------------------|---------------------------------------|
| 1) Max sewing speed:     | 4500rpm                               |
| 2) Stitch length:        | 0-5mm                                 |
| 3) Presser foot lift:    | 5mm (by hand)<br>13mm (by knee)       |
| 4) Needle bar stroke:    | 31.8mm                                |
| 5) Take-up lever stroke: | 58mm                                  |
| 6) Knife stroke: 5mm     |                                       |
| 7) Needle:               | DBx5 # 14                             |
| 8) Application:          | light to medium heavy weight material |
| 9) Reverse feed device:  | available                             |

## 2. MACHINE INSTALLATION

- 1) Put the rubber cushions to the four corners of the oil reservoir, then set the oil reservoir to the table.
- 2) Insert the hinge① to the hole for the hinge on the machine head, then set the machine head onto the rubber cushions and the hinge sockets② on the table.
- 3) Align Motor Pully Groove (B) and Balance Wheel Groove (A) by moving the motor(C) leftward or rightward.

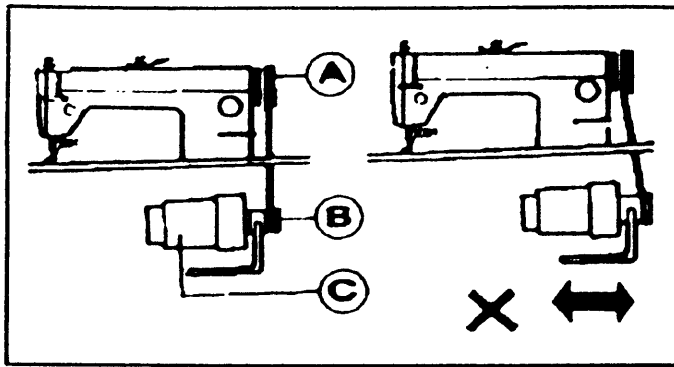
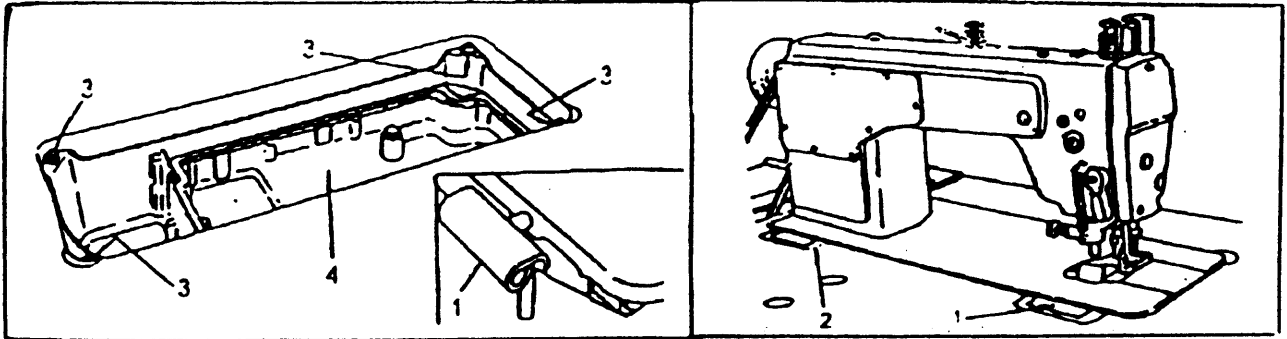

### 3. INSTALL BELT GUARD AND BOBBIN WINDER

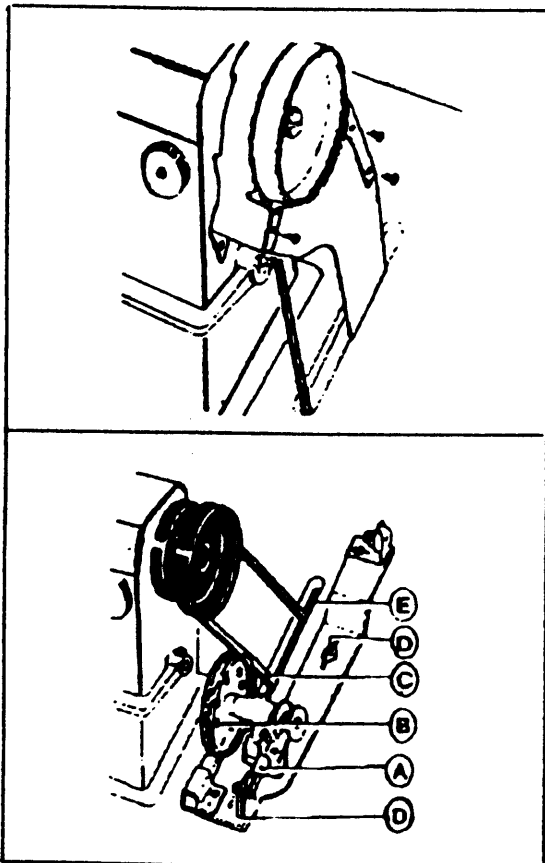

#### 1) Install the belt guard

For the sake of safety, the Belt Guard is essential.

#### 2) Install the bobbin winder.

Align Bobbin Winder pulley(B) and the outside edge of Belt(C), keeping a sufficient clearance between Bobbin Winder pulley and Belt to ensure they will keep in touch when Bobbin Winder Stop Latch Lever(A) is pressed down and rotate together when running the machine. Be sure to parallel the Bobbin Winder Pulley with Belt Slot(E) on the table and tighten Wood Screws(D) then.

#### 4. INSTALL CHIP RETAINING PLATE

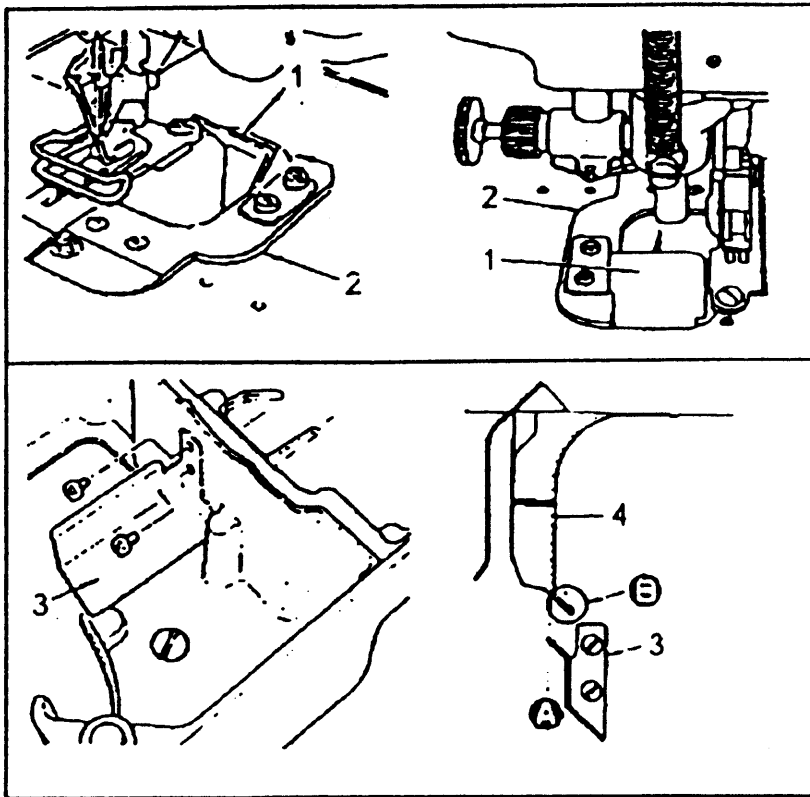

Install Chip Retaining Plate ① on Chip Funnel Plate ② to completely prevent chips from getting out. Then set the oil guide chute onto the oil reservoir as following:

- 1) The forepart of the oil guide chute mustn't stretch leftwards too far from the lengthened line of Plane (A).
- 2) Part (B) of the chip funnel won't touch the oil guide chute when turning up or down the machine head.

#### 5. CONNECT CLUTCH LEVER WITH PEDAL

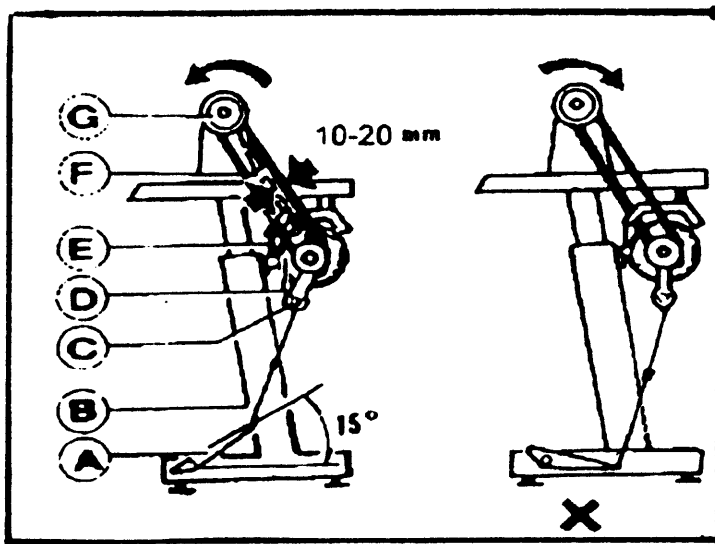

- 1) The optimum tilt angle of Pedal is approximately 15 deg.
- 2) Adjust Clutch Cover so that Clutch-lever and Draw bar run in line.
- 3) The balance wheel should rotate counter-clock wise when viewed from the outside of Balance wheel. The direction of motor pulley rotation can be reversed by reversing (turning over 180 deg) the power plug of the motor.

- 4) Adjust the tension of V-belt by moving the motor up and down. The proper tension of the V-belt is a slack of 10-20mm when the belt is depressed at the center of the belt by finger.

## 6.OILING

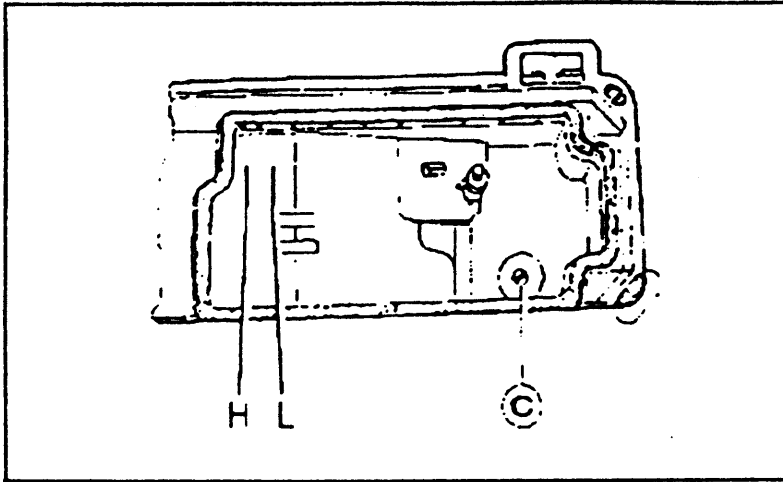

### 1) Required amount of oil

Line (H) on the oil reservoir:

Max. oil level

Line (L) on the oil reservoir:

Min. oil level

If oil level goes down under Line(L), oil can not be distributed to each part of the machine, thus causing the parts a seizure.

- 2) Always use 18# special machine oil for high speed sewing machine only. Be sure to replenish oil to Line (H) before operation.
- 3) To replace oil, loosen Screw(C) to drain used oil. After completely draining off oil, clean the oil reservoir and securely tighten Screw(C), then fill the reservoir with fresh oil.

## 7. RUN-IN OPERATION

Run-in operation is required for a new sewing machine, or a sewing machine left out of operation for a considerable length of time.

1) Remove Rubber Plugs(A) on the top of the arm and replenish sufficient amount of oil.

2) Lift Presser Foot(B)

3) Run the machine at a low speed (2000-2500spm) to check oil distributing condition through Oil Check Window(C).

4) Perform run-in operation at 2000-2500spm for 30 minutes. After a lapse of one month of service during which the working speed is increased gradually, the machine runs sufficiently well, and the high speed 4500spm can be adopted according to the nature of the work.

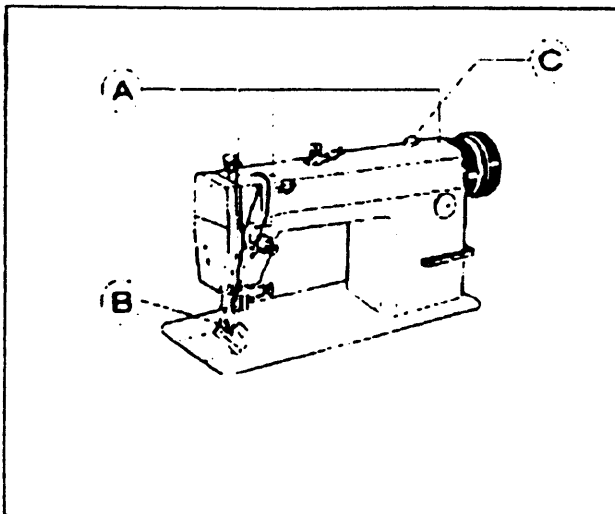

## 8. REPLACE NEEDLES

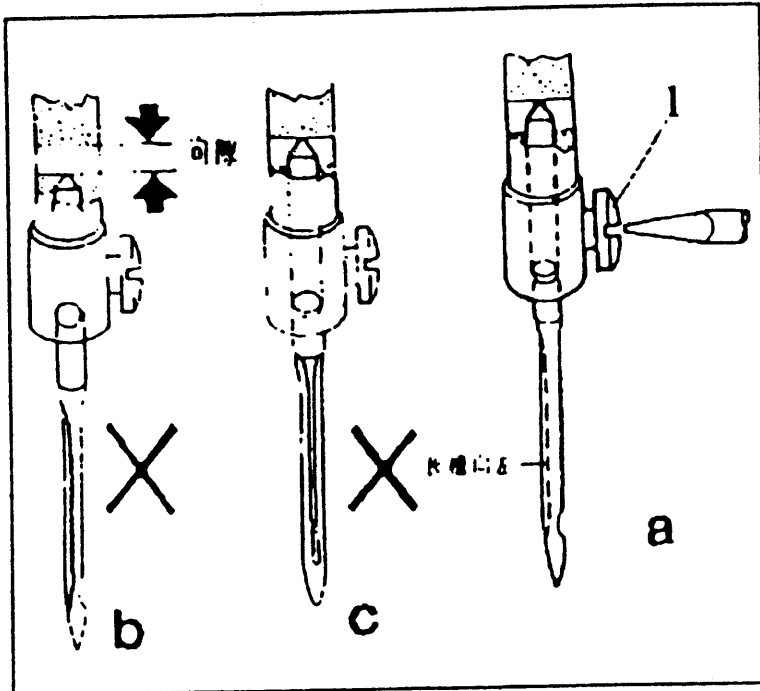

Turning the balance wheel to lift needle bar to the upper end of its stroke. Loosen Needle clamp Screw (1). While keeping the long groove of the needle leftward, fully insert the needle shank up to the bottom of the needle socket. Then tighten Needle clamp Screw (1). Note:

Fig.(b) insufficient insertion.

Fig.(c) wrong direction of long groove.

## 9. ADJUST PRESSURE AND HEIGHT OF PRESSER FOOT

### 1) Pressure adjustment:

Pressure of presser foot is to be adjusted according to the thickness of materials to be sewn.

Loosen Lock Nut (A) first. For heavy materials, turn the pressure regulating thumb screw as shown in Fig. (a) to increase the pressure, while for light materials, turn the pressure regulating thumb screw as shown in Fig. (b) to decrease the pressure. Then tighten Lock Nut (A).

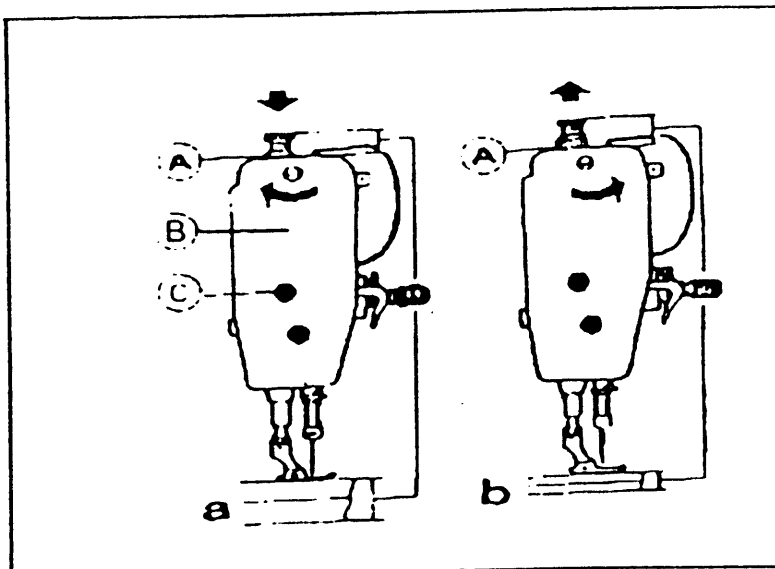

### 2) Height adjustment:

- 1) Remove Rubber plug (C) from Face plate (B).
- 2) Loosen screw of presser bar guide bracket and adjust the height of Presser Bar.
- 3) Tighten screw again and put in Rubber Plug(C).

## 10. THREADING

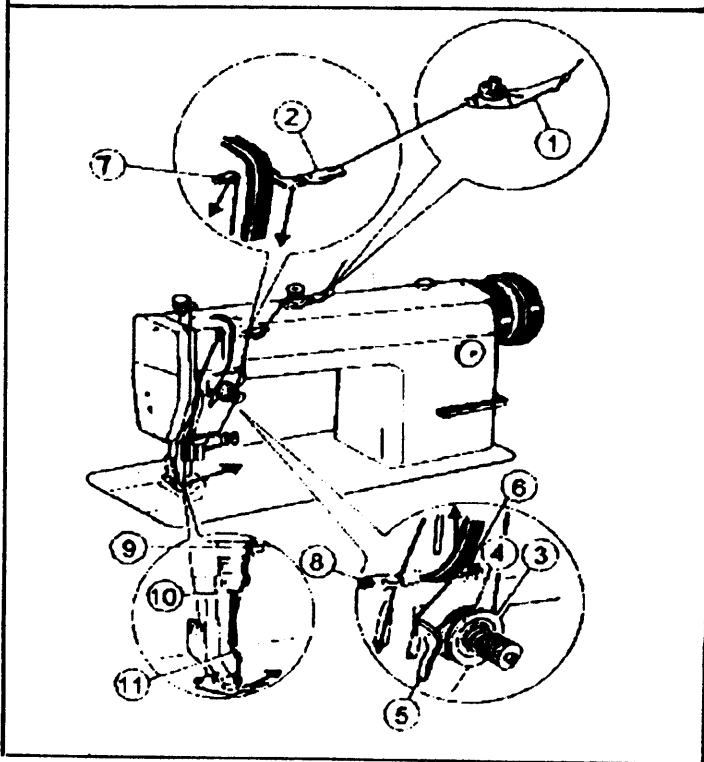

- 1) To thread the needle thread, raise needle bar to the upper end of its stroke, lead the thread from spool and perform threading as per threading sequence.
- 2) To draw the bobbin thread, hold the end of the needle thread and turn the balance wheel to lower the needle bar and then to lift it to its highest position. Pull the needle thread and the bobbin thread is drawn up. Put the ends of needle thread and bobbin thread frontward under presser foot.

## 11. ADJUST THREAD TENSION

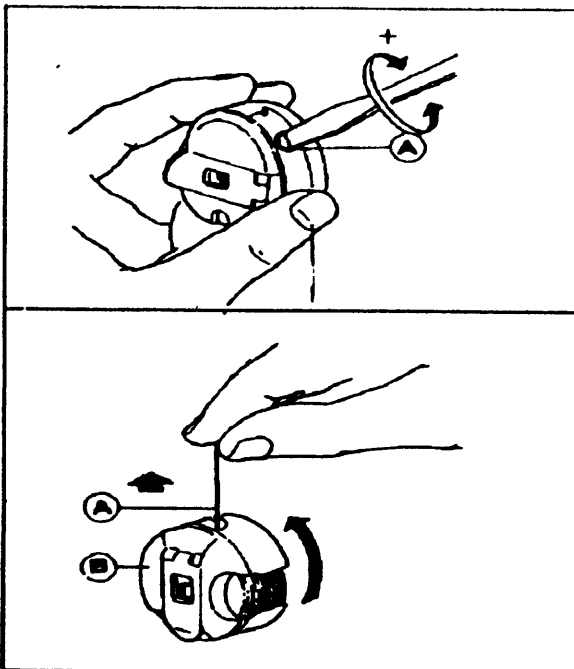

- 1) To adjust bobbin thread tension, turn Tension Spring Regulating Screw (A) of Bobbin case clockwise for more tension, or turn the screw counter – clockwise for less tension.
- 2) The needle thread tension should be adjusted with reference to the bobbin thread tension and it can be adjusted by setting the thread take-up spring tension, the thread take-up spring stroke and the position of thread tension discs or thread guide.

## 12. INSTALLATION AND OPERATION OF THE KNIFE

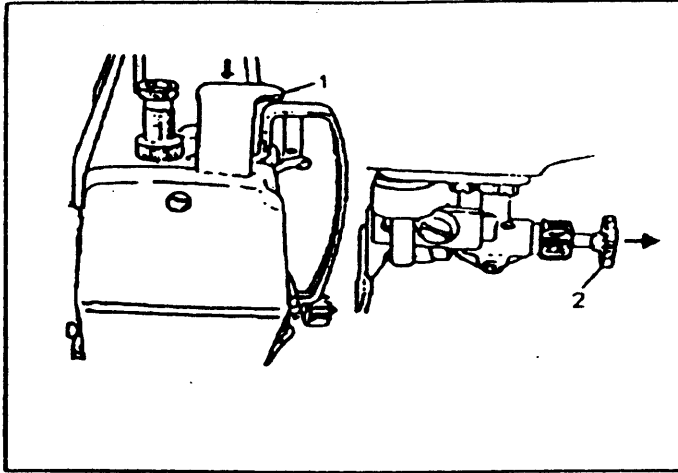

### Knife operation:

(1) To actuate the cutting knife, press down Knife operating plate (1) to lower the knife while running the sewing machine.

(2) To stop cutting of the knife for sewing only, pull out Knob(2) as indicated by the arrow.

### Knife installation:

Install the cutting knife as shown in the figure. When bringing the knife to the lowest position, move it up and down to make sure the part A of the knife is 0-0.5mm lower than the surface of the needle plate.

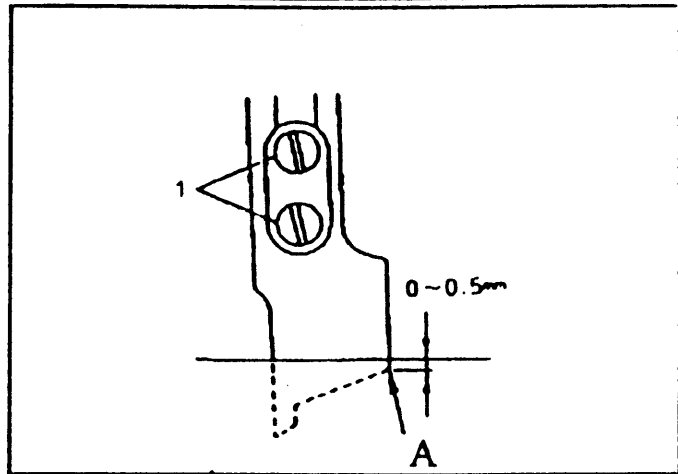

### Cutting width change:

(1) The cutting width can be varied by changing needle plate assy. When changing, loosen Set Screw(1) and pull out cutting knife parallelly to ensure a good cutting quality.

(2) Due to the change in the size of needle plate assy. you must change the position of the cutting knife accordingly. Loosen Screw(2) to make the edge of cutting knife touch the edge of needle plate assy, then tighten the screw again.

(3) 3.2mm is the standard specification of this needle plate assy.

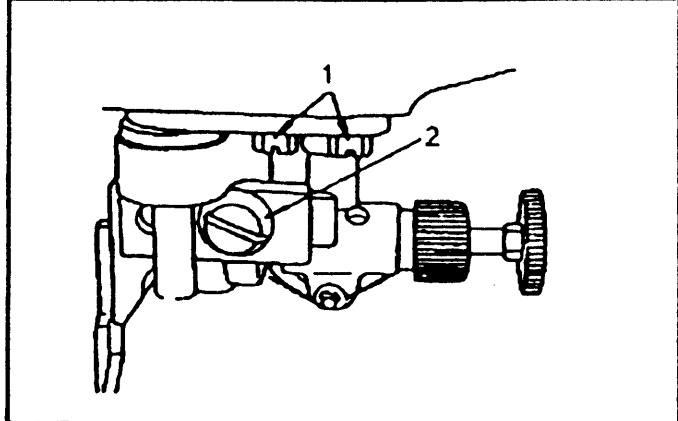



### 13. ADJUST TENSION OF NEEDLE & BOBBIN THREAD

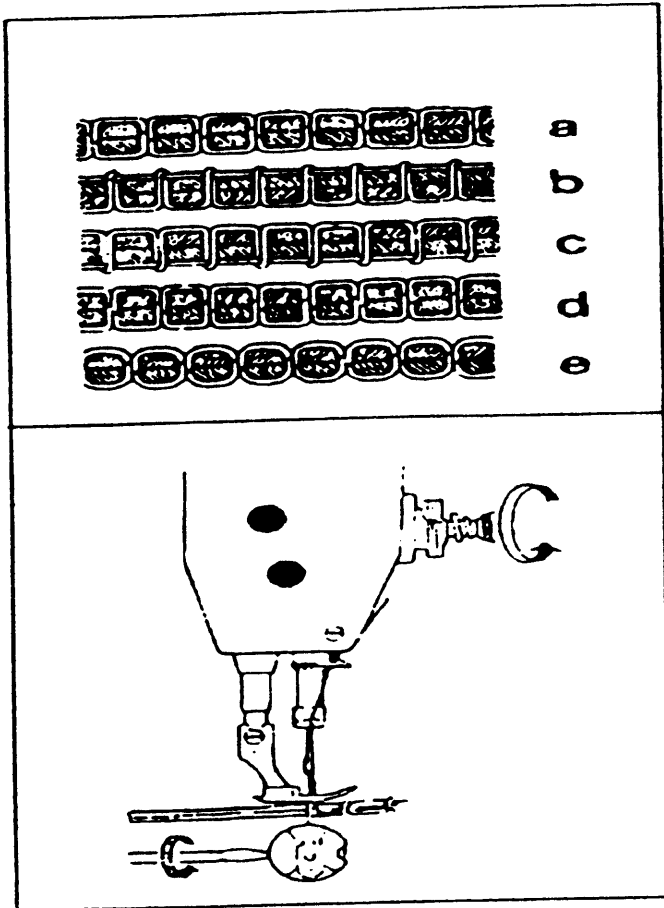

The position of the thread guide affects stitch tightness and therefore must be adjusted according to sewing material and sewing conditions. Fig. (a) shows the correct stitch. Abnormal stitches cause puckering and thread breakage. In such a case the tension of needle thread and bobbin thread must be adjusted accordingly.

1) In case of needle thread tension is too strong or bobbin thread tension is too weak, turn the thumb nut counterclockwise to decrease the needle thread tension, or tighten the tension spring regulating screw of bobbin case to increase the bobbin thread tension.

2) In case of needle thread tension is too weak or bobbin thread tension is too strong, turn the thumb nut clockwise to increase the needle thread tension, or loosen the tension spring regulating screw of bobbin case to decrease the bobbin thread tension.

3) In case of the stitch forms of "d" and "e", adjustments can be made with reference to the above means.

### 14. REPLACE OTHER PARTS

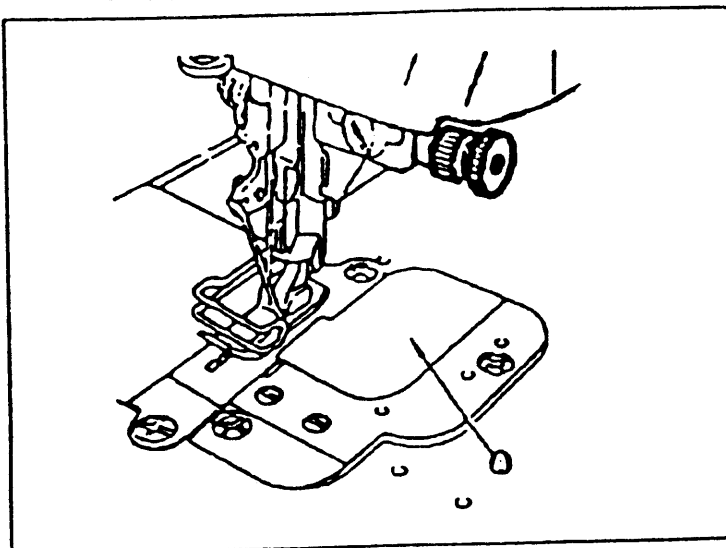

1) When not using the cutting knife, place the cover onto the opening A of the chip funnel.

2) After putting on the cover, the machine can sew only.

# 15. RELATED PARTS FOR CHANGING CUTTING WIDTH

NAME SPE WIDTH	NEEDLE PLATE	FEED DOG	PRESSER FOOT	KNIFE	CHIP FUNNEL	CHIP GUIDING PLATE	CHIP FUNNEL PLATE
3/32" (2.4mm)	3/32"	3/32"	1/8"	1/8"	1/8"	1/8"	1/8"
1/8" (3.2mm)	1/8"	1/8"	1/8"	1/8"	1/8"	1/8"	1/8"
(4mm)	5/32"	1/8"	1/8"	1/8"	1/8"	1/8"	1/8"
(4.8mm)	3/16"	1/8"	1/8"	1/8"	1/8"	1/8"	1/8"
(6.4mm)	1/4"	1/4"	1/4"	1/8"	1/4"	1/4"	1/8"
(9.5mm)	3/8"	3/8"	3/8"	1/8"	3/8"	3/8"	1/8"

# A: ARM BED AND ITS ACCESSORIES

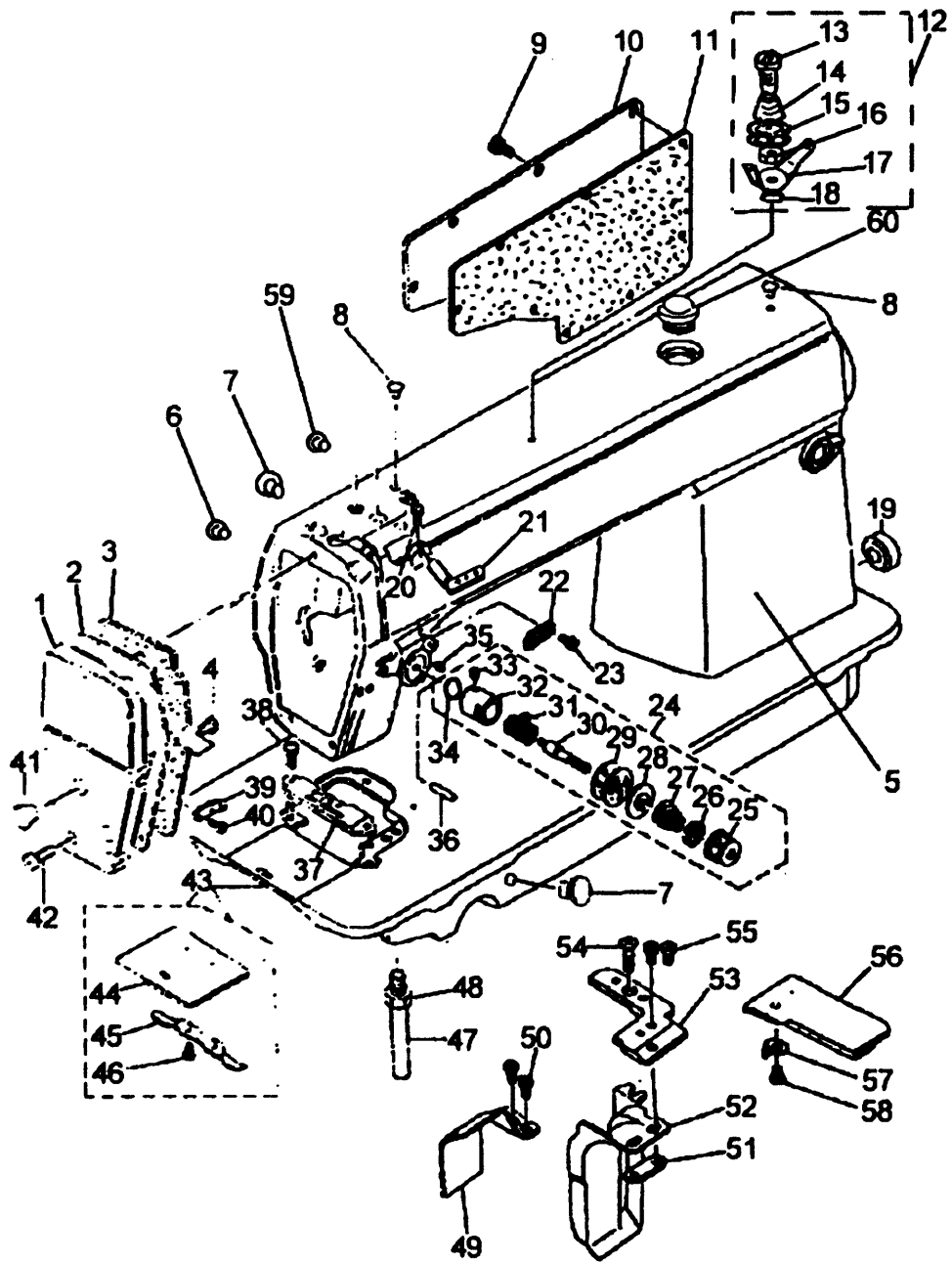

## A: ARM BED AND ITS ACCESSORIES

No.	Ref. No.	Name	Quantity
1	H57A001	Face plate	1
2	H57A002	Gasket for face plate	1
3	H57A003	Rubber spacer	1
4	H57A004	Screw	3
5	H57A005	Arm bed assy.	1
6	H57A006	Rubber plug( $\Phi$ 19)	1
7	H57A007	Rubber plug( $\Phi$ 11.8)	1
8	H57A008	Rubber plug( $\Phi$ 5.7)	1
9	H57A009	Screw	8
10	H57A010	Arm side cover	1
11	H57A011	Gasket for arm side cover	1
12	H57A012	Pre-tension assy.	1
13	H57A013	Pre-tension stud	1
14	H57A014	Spring for pre-tension	1
15	H57A015	Disc for pre-tension	2
16	H57A016	Spacer for pre-tension thread guide	1
17	H57A017	Stop ring	1
18	H57A018	Pre-tension thread guide	1
19	H57A019	Rubber plug( $\Phi$ 27)	1
20	H57A020	Three-hole thread guide	1
21	H57A021	Set screw	1
22	H57A022	Thread guide	1
23	H57A023	Screw	1
24	H57A024	Thread tension assy.	1
25	H57A025	Thumb nut	1
26	H57A026	Stop disc	1
27	H57A027	Thread tension spring	1
28	H57A028	Thread tension releasing disc	1
29	H57A029	Thread tension disc	1
30	H57A030	Thread tension stud	1
31	H57A031	Thread take-up spring	1
32	H57A032	Thread tension regulating bushing	1
33	H57A033	Set screw	1
34	H57A034	O-ring	1
35	H57A035	Set screw	1
36	H57A036	Thread tension releasing pin	1
37	H57A037	Needle plate	1
38	H57A038	Screw	2
39	H57A039	Thread guide on face plate	1

No.	Ref. No.	Name	Quantity
40	H57A040	Thread guide screw	1
41	H57A041	Rubber plug( $\Phi$ 11.8)	1
42	H57A042	Face plate screw	2
43	H57A043	Slide plate assy	1
44	H57A044	Slide plate	1
45	H57A045	Slide plate spring	1
46	H57A046	Screw	2
47	H57A047	Leg	3
48	H57A048	Washer	2
49	H57A049	Chip guide plate	1
50	H57A050	Screw	2
51	H57A051	Clip plate	1
52	H57A052	Chip funnel	1
53	H57A053	Chip funnel plate	1
54	H57A054	Screw	2
55	H57A055	Screw	2
56	H57A056	Chip funnel cover	1
57	H57A057	Spring for chip funnel cover	1
58	H57A058	Screw	2
59	H57A059	Rubber plug( $\Phi$ 8.8)	2
60	H57A060	Oil window	1



## B: ARM SHAFT ,VERTICAL SHAFT AND THREAD TAKE-UP MECHANISM.

No.	Ref. No.	Name	Quantity
1	H57B001	Thread take-up lever	1
2	H57B002	Thread take-up lever link	1
3	H57B003	Hinge pin	1
4	H57B004	Crank	1
5	H57B005	Needle bearing	2
6	H57B006	Set screw(counter-clockwised)	1
7	H57B007	Needle bar link	1
8	H57B008	Needle bar adaptor	1
9	H57B009	Set screw	1
10	H57B010	Set screw	1
11	H57B011	Thread take-up guard	1
12	H57B012	Screw	1
13	H57B013	Needle bar crank	1
14	H57B014	Set screw	1
15	H57B015	Set screw	2
16	H57B016	Set screw	1
17	H57B017	Needle bar bushing(upper)	1
18	H57B018	Rubber plug	1
19	H57B019	Needle bar bushing(lower)	1
20	H57B020	Thread guide for needle bar bushing	1
21	H57B021	Needle bar	1
22	H57B022	Thread guide for needle bar	1
23	H57B023	Needle	1
24	H57B024	Needle clamp screw	1
25	H57B025	Guide for slide block	1
26	H57B026	Set screw	2
27	H57B027	Slide block	1
28	H57B028	Arm shaft	1
29	H57B029	Rubber plug( $\Phi 7.4 \times 10$ )	2
30	H57B030	Collar for arm shaft	1
31	H57B031	Set screw	2
32	H57B032	Arm shaft bushing(left)	1
33	H57B033	Arm shaft bushing(middle)	1
34	H57B034	Set screw	1
35	H57B035	Arm shaft bushing(right)	1
36	H57B036	Oil seal	1
37	H57B037	balance wheel	1

No.	Ref. No.	Name	Quantity
38	H57B038	Set screw	2
39	H57B039	Screw	1
40	H57B040	Feed and feed lifting eccentric	1
41	H57B041	Washer	3
42	H57B042	Screw	2
43	H57B043	Set screw	1
44	H57B044	Connecting rod for feed lifting	1
45	H57B045	Connecting rod for feeding	1
46	H57B046	Felt plug	1
47	H57B047	Seal ring	1
48	H57B048	Rubber ring	1
49	H57B049	Oil adjusting stud	1
50	H57B050	Vertical shaft	1
51	H57B051	Bevel gear for arm shaft	1
52	H57B052	Bevel gear for vertical shaft(upper)	1
53	H57B053	Set screw	8
54	H57B054	Bevel gear for hook shaft	1
55	H57B055	Bevel gear for vertical shaft(lower)	1
56	H57B056	Vertical shaft bushing(upper)	1
57	H57B057	Vertical shaft bushing(lower)	1
58	H57B058	Set screw	2



# C: FEED, FEED LIFTING AND ROTATING HOOK MECHANISM

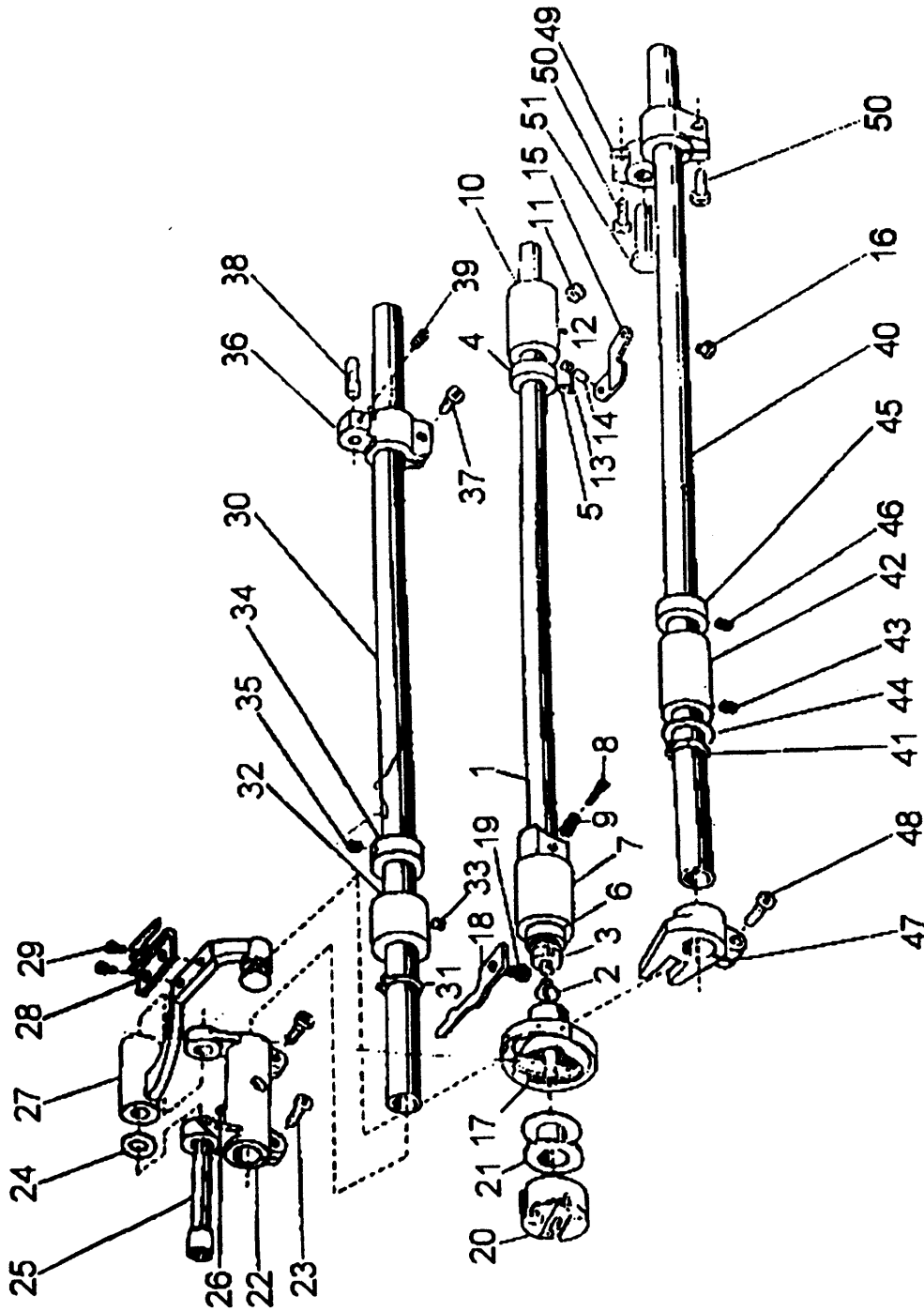

## C: FEED,FEED LIFTING AND ROTATING HOOK MECHANISM

No.	Ref. No.	Name	Quantity
1	H57C001	Hook shaft	1
2	H57C002	Filter screw	1
3	H57C003	Filter	1
4	H57C004	Collar for hook shaft	1
5	H57C005	Set screw	2
6	H57C006	Oil seal for rotating hook shaft	1
7	H57C007	Hook shaft bushing(left)	1
8	H57C008	Oil adjusting screw	1
9	H57C009	Spring for oil adjuster	1
10	H57C010	Hook shaft bushing(right)	1
11	H57C011	Screw for hook shaft bushing(right)	1
12	H57C012	Oil pipe for hook shaft bushing	1
13	H57C013	Plunger	1
14	H57C014	Plunger spring	1
15	H57C015	Guide plate	1
16	H57C016	Screw	1
17	H57C017	Rotating hook complete	1
18	H57C018	Rotating hook positioner	1
19	H57C019	Screw	1
20	H57C020	Bobbin case	1
21	H57C021	Bobbin	1
22	H57C022	Crank for feed bar	1
23	H57C023	Screw	2
24	H57C024	Washer	1
25	H57C025	Eccentric shaft for feed bar crank	1
26	H57C026	Screw	1
27	H57C027	Feed bar	1
28	H57C028	Feed dog	1
29	H57C029	Screw	2
30	H57C030	Feed rock shaft	1
31	H57C031	C-type stop ring	1
32	H57C032	Bushing for feed rock shaft	1
33	H57C033	Set screw	1
34	H57C034	Collar	1
35	H57C035	Set screw	2
36	H57C036	Feed rock shaft crank(right)	1
37	H57C037	Screw	1

No.	Ref. No.	Name	Quantity
38	H57C038	Short pin	1
39	H57C039	Set screw	1
40	H57C040	Feed lifting rock shaft	1
41	H57C041	C-type stop ring	1
42	H57C042	Bushing for feed lifting rock shaft	1
43	H57C043	Set screw	1
44	H57C044	Washer	1
45	H57C045	Collar for feed lifting rock shaft	1
46	H57C046	Screw	2
47	H57C047	Feed lifting rock crank	1
48	H57C048	Screw	1
49	H57C049	Feed lifting rock shaft crank(right)	1
50	H57C050	Screw	2
51	H57C051	Hinge pin	1

## D: STITCH LENGTH REGULATING MECHANISM

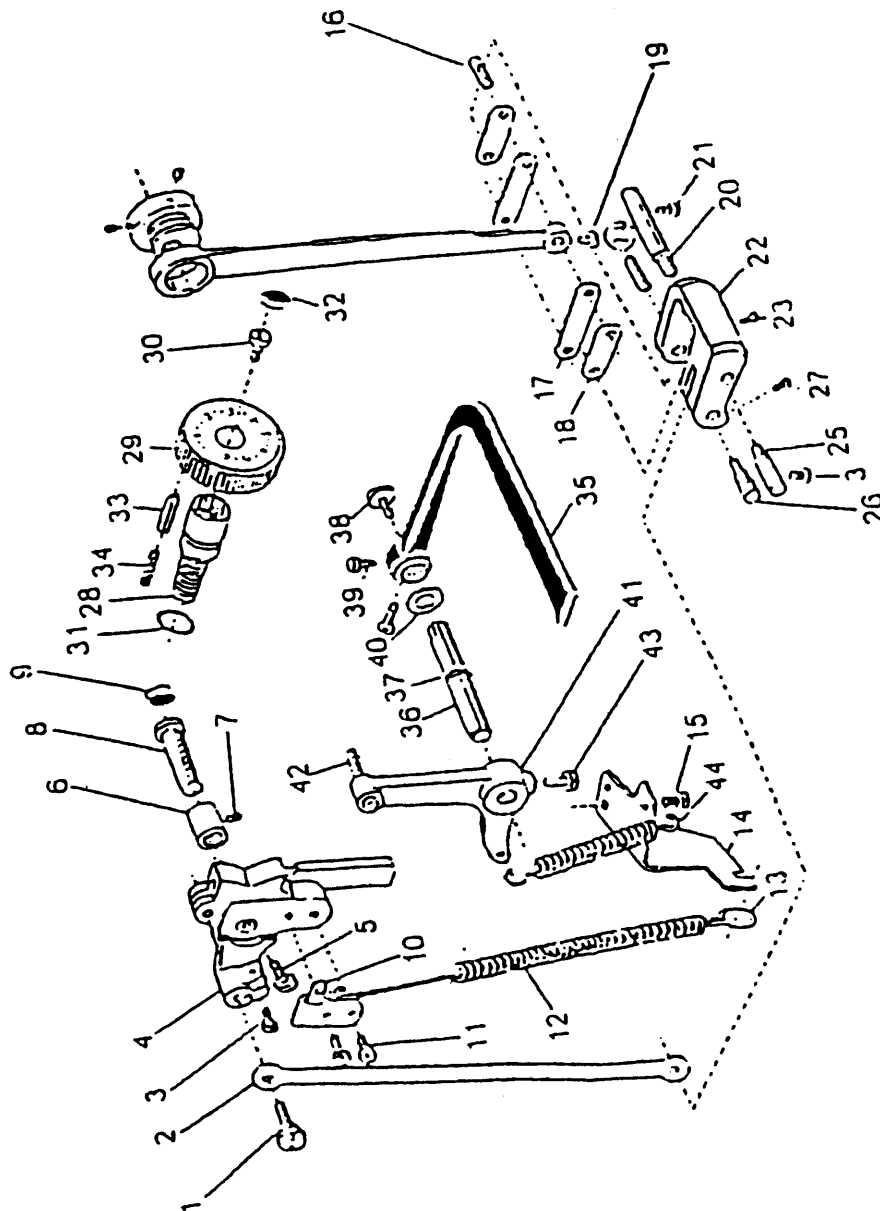

## D: STITCH LENGTH REGULATING MECHANISM

No.	Ref. No.	Name	Quantity
1	H57D001	E-type stop ring	1
2	H57D002	Stitch regulating link	1
3	H57D003	Feed regulating rocker pin	1
4	H57D004	Feed regulating rocker	1
5	H57D005	Screw	1

No.	Ref. No.	Name	Quantity
6	H57D006	Feed regulating rocker bushing	1
7	H57D007	Set screw	1
8	H57D008	Hinge pin for feed regulating rocker	1
9	H57D009	Rubber plug( $\phi$ 20 · 6)	1
10	H57D010	Bracket for spring	1
11	H57D011	Screw	1
12	H57D012	Spring	2
13	H57D013	Hook for spring	2
14	H57D014	Bracket for spring	1
15	H57D015	Screw	1
16	H57D016	Pin	1
17	H57D017	Crank link(long)	1
18	H57D018	Crank link(short)	1
19	H57D019	Screw	1
20	H57D020	Stud pin(right)	1
21	H57D021	Screw	1
22	H57D022	Stitch regulating crank	1
23	H57D023	Screw	1
24	H57D024	Pin	1
25	H57D025	Stud pin(left)	1
26	H57D026	Eccentric stud	1
27	H57D027	Screw	1
28	H57D028	Screw bar	1
29	H57D029	Stitch dial	1
30	H57D030	Screw	1
31	H57D031	O-ring	1
32	H57D032	Rubber plug	1
33	H57D033	Stop pin	2
34	H57D034	Spring	1
35	H57D035	Reverse feed lever	1
36	H57D036	Short shaft	1
37	H57D037	O-ring	1
38	H57D038	Set screw	1
39	H57D039	Screw	1
40	H57D040	Washer	1
41	H57D041	Crank for feed reverse lever	1
42	H57D042	Slide block stud	1
43	H57D043	Screw	1
44	H57D044	Spring	1

## E: KNIFE CONTROL MECHANISM

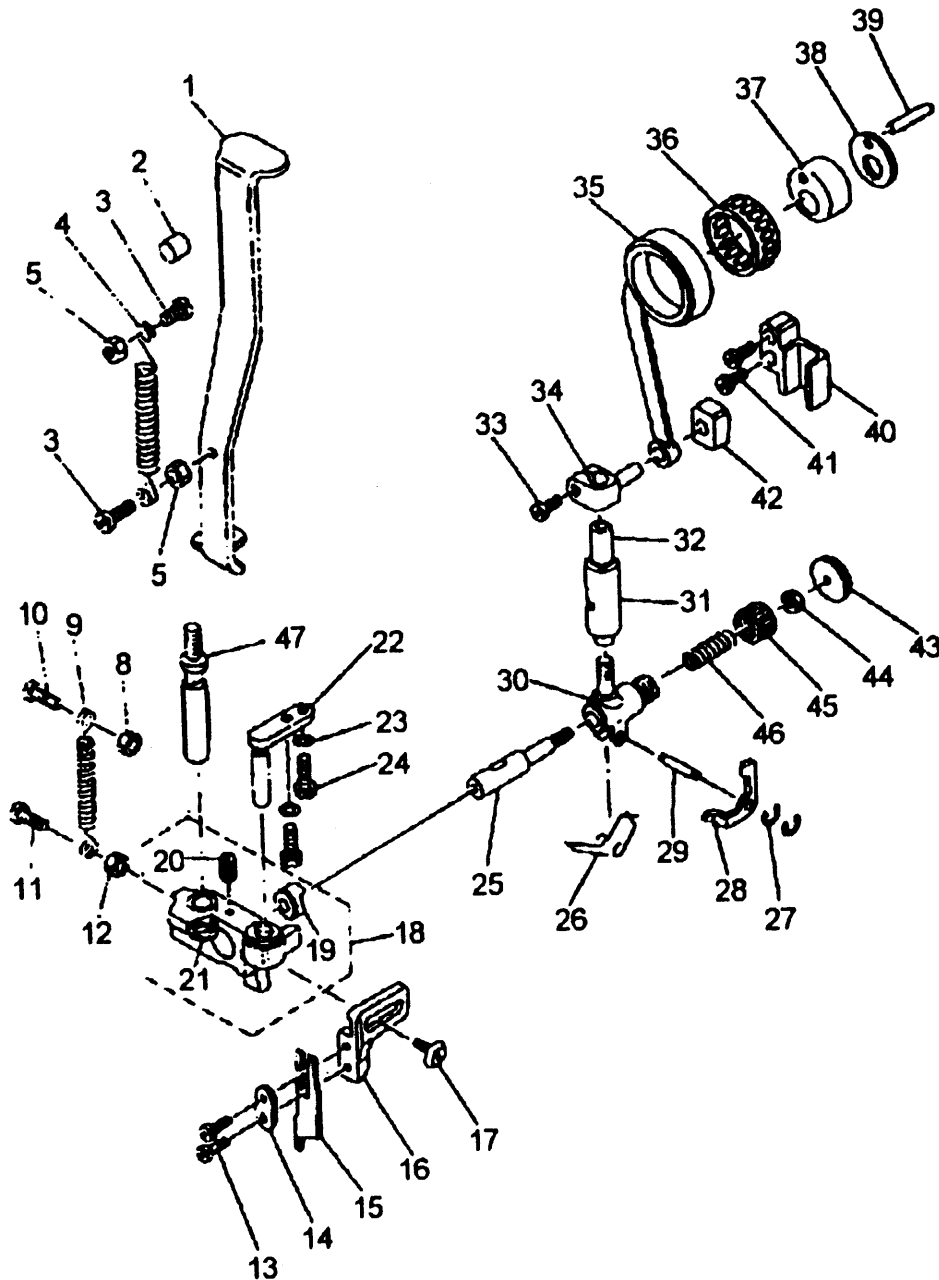

## E: KNIFE CONTROL MECHANISM

No.	Ref. No.	Name	Quantity
1	H57E001	Operating lever for knife	1
2	H57E002	Felt	1
3	H57E003	Screw	2

No.	Ref. No.	Name	Quantity
4	H57E004	Spring for knife operating lever	1
5	H57E005	Nut	2
8	H57E008	Nut(upper)	1
9	H57E009	Spring	1
10	H57E010	Screw(upper)	1
11	H57E011	Screw	1
12	H57E012	Nut	1
13	H57E013	Set screw	2
14	H57E014	Gasket	1
15	H57E015	Cutting knife	1
16	H57E016	Knife holder	1
17	H57E017	Screw	1
18	H57E018	Guide bracket	1
22	H57E022	Guiding block	1
23	H57E023	Washer	2
24	H57E024	Set screw	2
25	H57E025	Pin	1
26	H57E026	Spring	1
27	H57E027	E-type ring	2
28	H57E028	Lever for knife	1
29	H57E029	Pin	1
30	H57E030	Guiding bushing	1
31	H57E031	Bushing for knife bar	1
32	H57E032	Knife bar	1
33	H57E033	Screw	1
34	H57E034	Knife bar adaptor	1
35	H57E035	Connecting rod	1
36	H57E036	Needle bearing	1
37	H57E037	Eccentric cam	1
38	H57E038	Thrust plate	1
39	H57E039	Pin	1
40	H57E040	Guide rail	1
41	H57E041	Set screw	2
42	H57E042	Slide block	1
43	H57E043	Knob	1
44	H57E044	Nut	1
45	H57E045	Cap	1
46	H57E046	Spring	1
47	H57E047	Guide plunger	1





## F: KNIFE CONTROL MECHANISM

No.	Ref. No.	Name	Quantity
1	H57F001	Presser bar lifter	1
2	H57F002	Set screw	1
3	H57F003	Presser bar lifting cam	1
4	H57F004	O-ring	1
5	H57F005	Knee lifter lever(left)	1
6	H57F006	Tension releasing cam	1
7	H57F007	Screw	1
8	H57F008	Screw	1
9	H57F009	Knee lifter rod	1
10	H57F010	Screw	1
11	H57F011	Tension releasing pin	1
12	H57F012	Knee lifter lever(right)	1
13	H57F013	Spring	2
14	H57F014	Bolt for knee lifter lever	1
15	H57F015	Knee lifter connecting rod	1
16	H57F016	Pin for spring	1
17	H57F017	Presser bar bushing	1
18	H57F018	Presser bar	1
19	H57F019	Presser bar lifting bracket	1
21	H57F021	Presser bar guide	1
22	H57F022	Spring for presser bar	1
23	H57F023	Lock nut	1
24	H57F024	Pressure regulating thumb screw	1
25	H57F025	Upper thread guide	1
26	H57F026	Screw	1
28	H57F028	Screw	1
29	H57F029	Presser foot assy.	1

# G: LUBRICATION MECHANISM

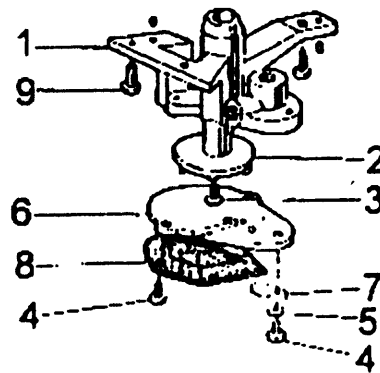
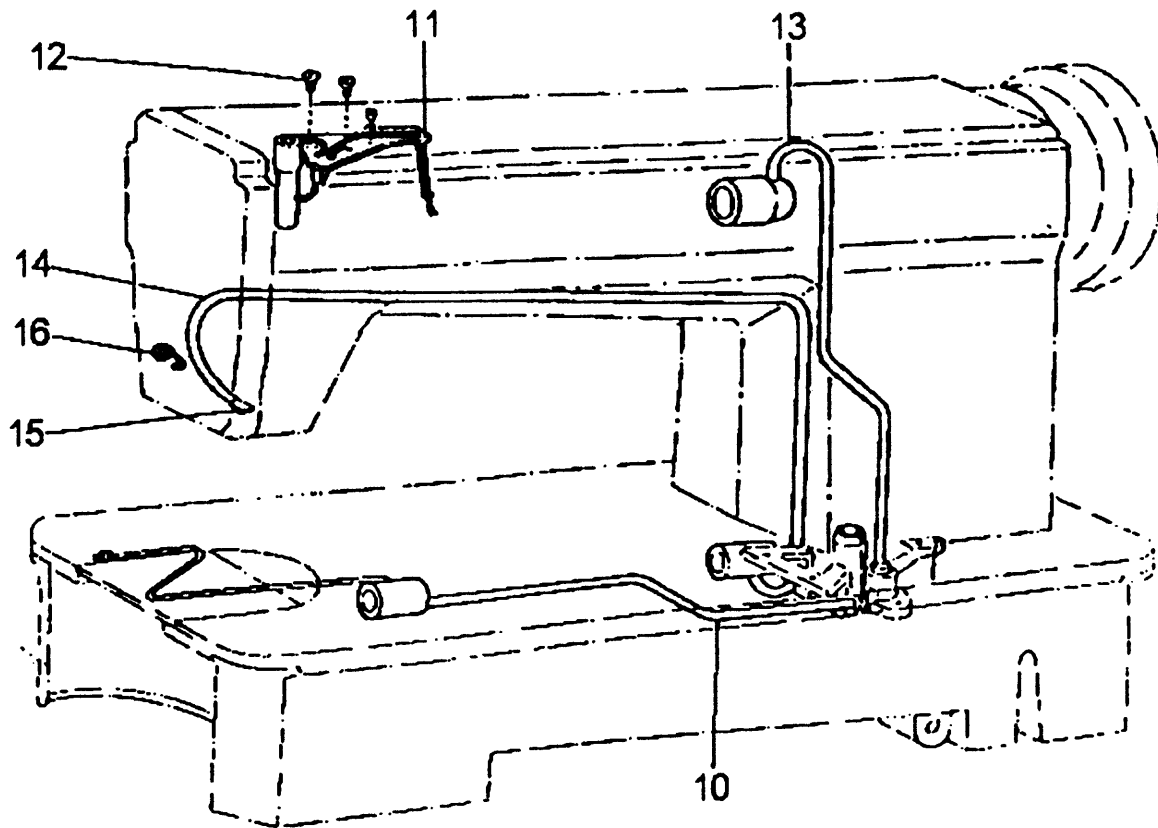

## G: LUBRICATION MECHANISM

No.	Ref. No.	Name	Quantity
1	H57G001	Oil pump body	1
2	H57G002	Oil pump impeller	1
3	H57G003	Screw	1
4	H57G004	Screw	3
5	H57G005	Spring washer	1
6	H57G006	Oil pump fitting plate	1
7	H57G007	Oil adjusting plate	1
8	H57G008	Oil pump screen assy.	1
9	H57G009	Screw	3
10	H57G010	Oil pipe for hook shaft	1
11	H57G011	Oil braid fitting plate	1
12	H57G012	Screw	2
13	H57G013	Oil pipe for arm shaft	1
14	H57G014	Oil return pipe	1
15	H57G015	Felt pouch	1
16	H57G016	Pipe holder	1

# H: OTHER ACCESSORIES

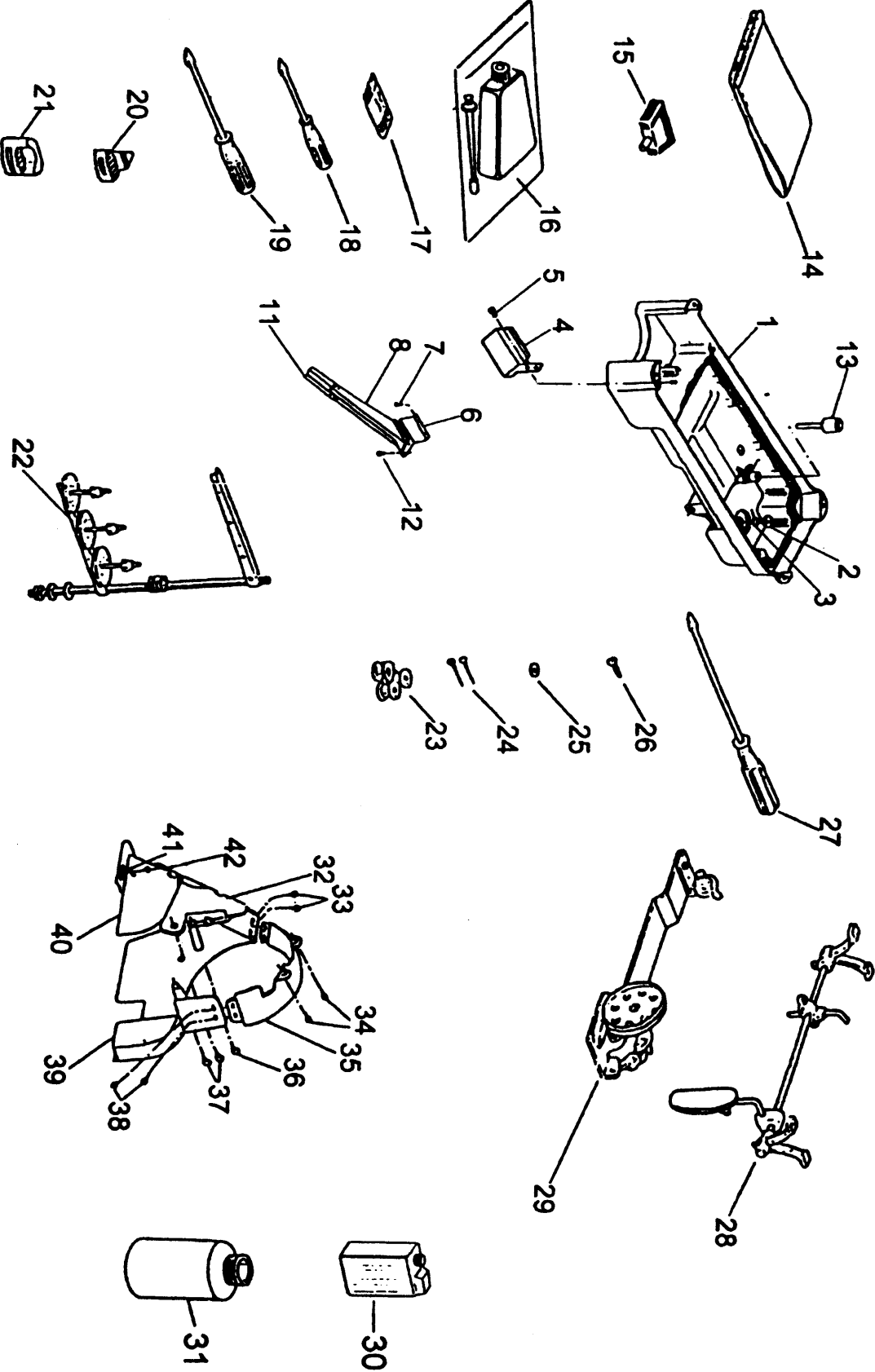

## H: OTHER ACCESSORIES

No.	Ref. No.	Name	Quantity
1	H57H001	Oil reservoir assy.	1
2	H57H002	Oil drain screw	1
3	H57H003	Washer	1
4	H57H004	-Oil guide	1
5	H57H005	Set screw	2
6	H57H006	Bracket for chip chute	1
7	H57H007	Wood screw	3
8	H57H008	Chip chute(big)	1
11	H57H011	Chip chute(small)	1
12	H57H012	Screw	4
13	H57H013	Knee lifter lifting rod	1
14	H57H014	Vinyl cover	1
15	H57H015	Hinge assy.	2
16	H57H016	Oiler	1
17	H57H017	Needle	1
18	H57H018	Screw driver(short)	1
19	H57H019	Screw driver(medium)	1
20	H57H020	Rubber cushion(small)	2
21	H57H021	Rubber cushion(big)	2
22	H57H022	Thread spool stand	1
25	H57H025	Washer	2
26	H57H026	Wood screw	2
27	H57H027	Screw driver(long)	1
28	H57H028	Knee lifter bell assy.	1
29	H57H029	Bobbin winder assy.	1
30	H57H030	Oil container	1
32	H57H032	Belt cover assy.	1
33	H57H033	Screw	2
34	H57H034	Belt cover assy.	1
35	H57H035	Screw	1
36	H57H036	Screw	2
37	H57H037	Belt cover	1
38	H57H038	Washer	2
39	H57H039	Wood screw	2